

Electric explosion  
and sparkproof hoists

Explosion and sparkproof  
lifting components



# products catalog

---

# Leading French manufacturer of lifting equipment

Leading French manufacturer of lifting equipment, VERLINDE's long production runs include electric belt hoists, electric winches, jib cranes and crane components in their VERNOUILLET (France) production centre. From CAD/CAM design to production by machines amongst the most modern in Europe combined with the know-how of skilled staff, every VERLINDE brand lifting unit ensures reliability and quality for users.



## New regulations, new products

VERLINDE have designed a range of explosion and spark proof hoists, with a close awareness of their customer's requirements, for use in many different fields such as food industry, chemicals, petrol, gas industries, and any environment where safety in production is a key concern. This range of lifting units is now manufactured to comply with the new ATEX 100a (94/09/EC directive applicable in 2003) and the EC standard (EC marking, EC documentation, EC inspection certificate, EC compliance approval). To comply with requirements of the ATEX 100 directive equipment is classified into 5 categories according to the explosion risk level in the working area.

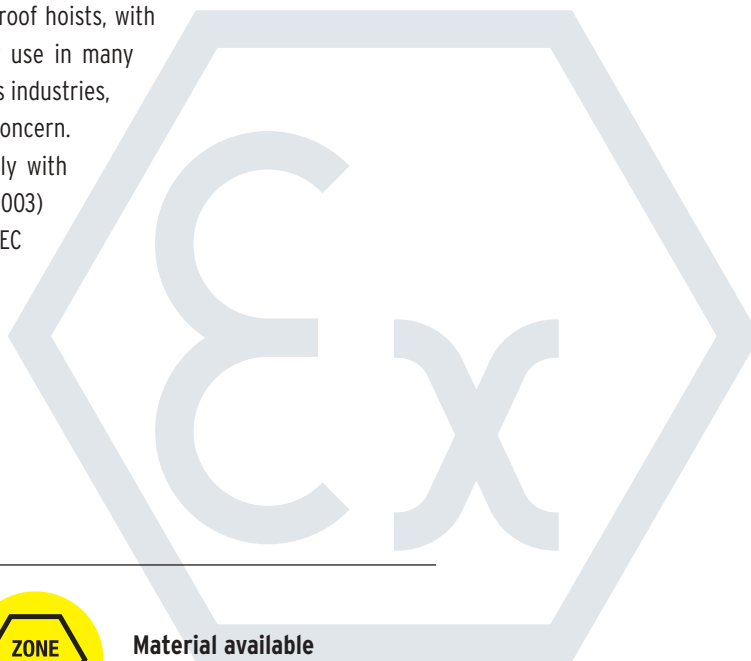

### Symbols



Material available in explosion proof version



Material available in Zone 22 version



Material available in sparkproof version



Material in compliance with the new ATEX 100a directive (94/09/EC applicable en 2003)





# EUROBLOC® VT

Electric sparkproof wire rope hoist

For loads from

# 800 to 80,000 kg



## Main technical features

- Protection rating :  
Ex II 3G c IIB T3 (Zone 2) as standard
- 2-speed hoisting motor with thermistors
- 2-speed pole change trolley motors with thermistors (for hoists with trolley)
- Hoist upper and lower limit switches operated by the rope guide
- Electro-mechanical overload protector
- Hoist electrics with main contactor and 48 V contactor control
- Motor protection IP66 according to EN 60 529
- Push button box with an emergency "stop" button
- Ergonomical hook with safety latch
- Galvanised wire rope
- Operation hours meter

## Options

- Protection zone 21/22
- Protection zone 2 II C T3
- Protection EEx de IIC T4 (instead of IIB)
- Ramshorn hook
- Non-rotating hook
- Remote control systems
- Travelling limit switch
- Special rail gauge for crab trolley
- Non standard rail width for monorail trolley
- Greater safety :
  - Bronze travelling wheels
  - Bronze roller anti rail jump, non ferrous metal plated
  - Bronzed hook



# EUROBLOC® VT



## Rope guide

New "very high performance" cable guide system. No guide system fouling to enable operation in the most difficult environments. Galvanized steel rope as standard with high safety factor (factor 4.6).



## Limit switch

The limit switches, accessed on the front face of the drum, manage the hook's upper and lower limit switches.

**Trolleys and pole change motors**  
Tropicalized motor as standard for longer life span.  
Special Ex bronze treatment of wheels (option).  
Optimal positioning of trolley wheels.  
The 4 trolley wheels share the load exactly to optimize your rail gauge.



## Hook and pulley block

Special Ex bronze treatment of hook (option) Small space requirements, bearings lubricated for life, GGG forged iron pulleys, ultra resistant. The high wire rope/pulley diameter ratio increases wire rope life span. Rotating hook and pulley block with safety latch.

## Sparkproof hoist motor

- Special design for explosion proof lifting (ATEX).
- 2 hoist speeds for greater precision.
- Motor cooling increased by 30 % (tunnel effect).



# Electric sparkproof wire rope hoist

For loads from

# 800 to 80,000 kg



### Sparkproof hoist motor

Tropicalized motor as standard for longer life span. Power rating 60 % motor cooling increased by 30 % (tunnel effect).

### New generation hoist drum

The very high wire rope/drum ratio (twice the standard ratio) increases wire rope life span and reduces "C" approach data of the hook. The best "C" factor on the market for optimal use of the size of your buildings and optimal use of work areas (save in building costs).



### Explosion proof electric cubicle

The electric cubicle provides protection rating IP 65 as standard. Low voltage control for greater safety.



### VT design

"VT new concept" The pulley block presents only a slight lateral shift during hoisting motion (virtually vertical lifting) for a fine positioning of your load.

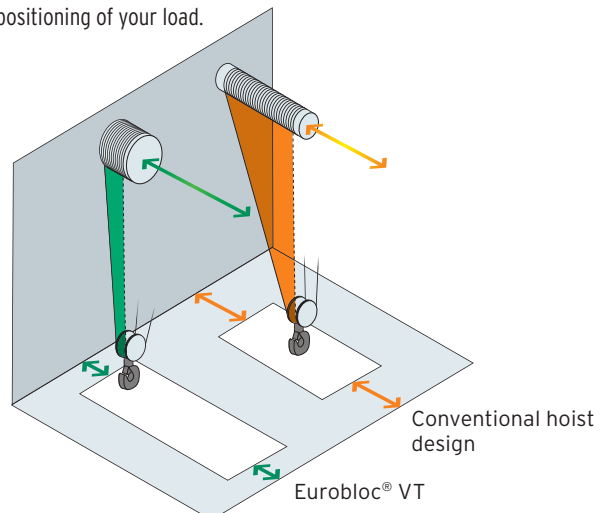



# EUROCHAIN<sup>®</sup> VL

Electric sparkproof chain hoist

For loads from

# 125 to 10,000 kg



**EUROCHAIN**  
**VL**   
**Zone 1**

## Main technical features

- An ideal solution for low and medium capacities from 125 to 10,000 kg
- Hook suspended model or with push or electric trolley
- Protection rating as standard : Zone 1, EEx de IIB T4 in compliance with EN/DIN
- Standard height of lift 3 m
- 2 hoist speeds (standard XCC : 2 speeds)
- 2 trolley motor speeds (standard XCC : 2 speeds)
- IP55-speed hoisting motors with thermistors
- Galvanised load chain
- Stainless steel hand chain if chain travel trolley
- Pendant push button box + control cable 2.5 m
- 4 buttons pendant for hoist attached to electric trolley
- 6 button box on hoist attached to electric trolley
- Power supply 400 V / 3Ph / 50 Hz or 415 V / 3Ph / 50 Hz
- Low voltage control 48 V
- Torque limiter
- Chain collector
- Emergency stop button with main contactor
- Epoxy paint with 5 year guarantee

## Options

- Protection EEx de IIC IIC T4 (instead of IIB) / Zone 21 / Zone 22
- Lifting upper and lower limit switch
- Travel limit switch
- Special trolley speed
- Monorail bogie trolley
- Monorail short headroom trolley
- Keylock on push button box
- Time meter
- Special supply voltage
- Remote control
- Non-standard IP protection rating
- Special paint
- Stainless steel load chain
- Greater sparkproof protection : bronze travelling wheels, bronze roller anti rail jump, non-ferrous metal plated, bronzed hook, bronze load and return wheels



**EUROCHAIN**  
**VL**   
**Zone 22**

 **VERLINDE**  
TECHNOLOGIES



# EUROCHAIN® V/L



## Limit switch

Electric cam limit switch (option) ensures safety of hoist operations. The user can now focus his attention on load travel.

## Explosion proof electric cubicle

Quite large, built into the equipment, it contains all the components (plate, contactors, transformer, etc.) and is easy to access for maintenance purposes, IP55 protection.



## Motor

Electro-magnetic disc brake type with linings material designed for lifespan of hoist FEM groups, easy to access and adjust.



# Electric sparkproof chain hoist

For loads from

# 125 to 10,000 kg



## Gear box

Improved hoist compactness. Low noise level when running thanks to grease-lubricated pinions and rectified, treated straight teeth.



## Load wheel

5 or 6 pockets (depending on model), treated and rectified, machined in a single operation.

## Chain guide

Ensures precise positioning of the chain guide on the load wheel.



## Hook and block

Special Ex. bronze treatment of hook. Small space requirements. Rotary lifting hook in special steel, complies with DIN standards, fitted with a hook with safety latch.



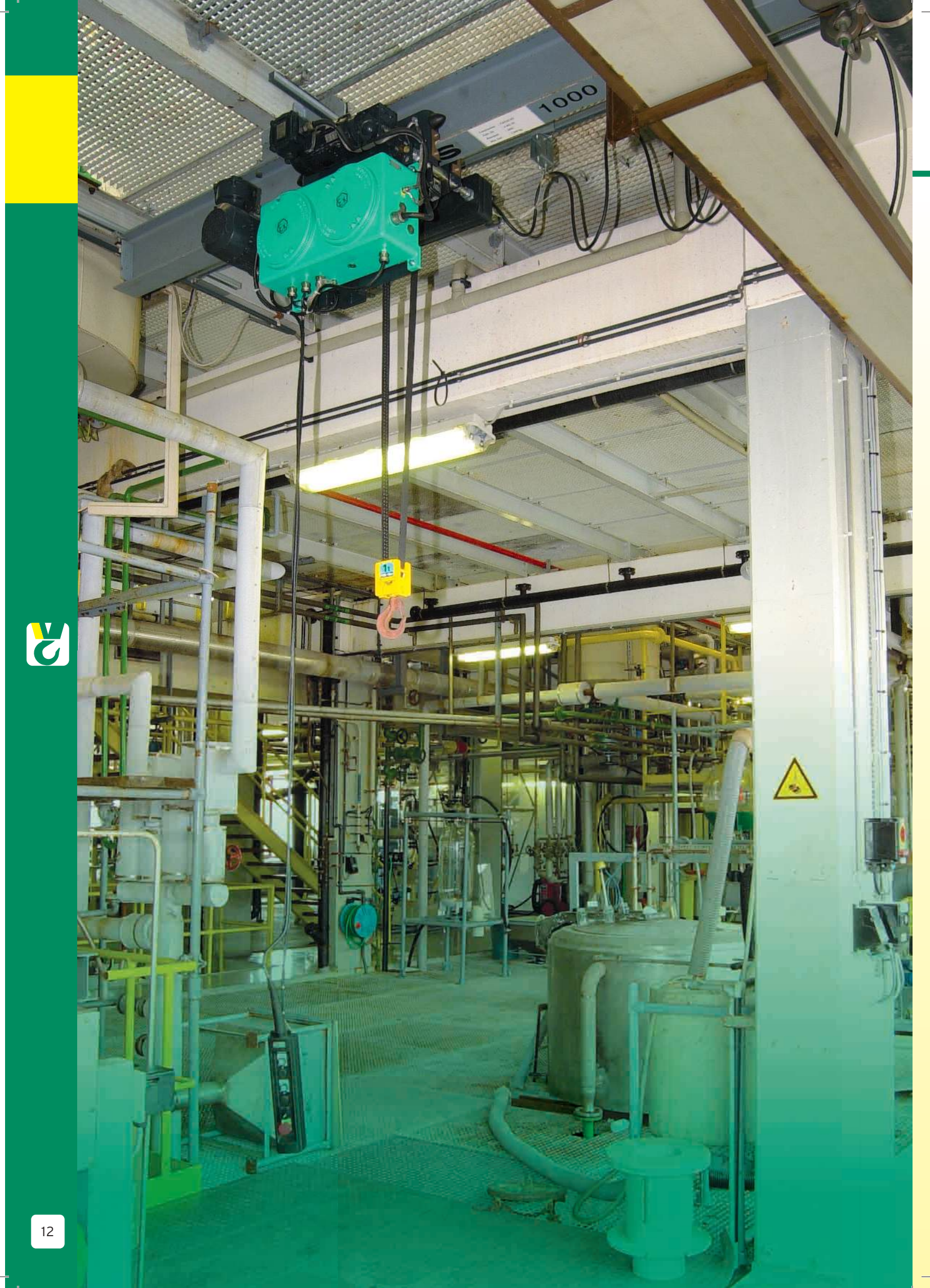

1000



# EUROLIFT® BH

Explosion proof electric belt hoist

For loads from

# 500 to 5,000 kg

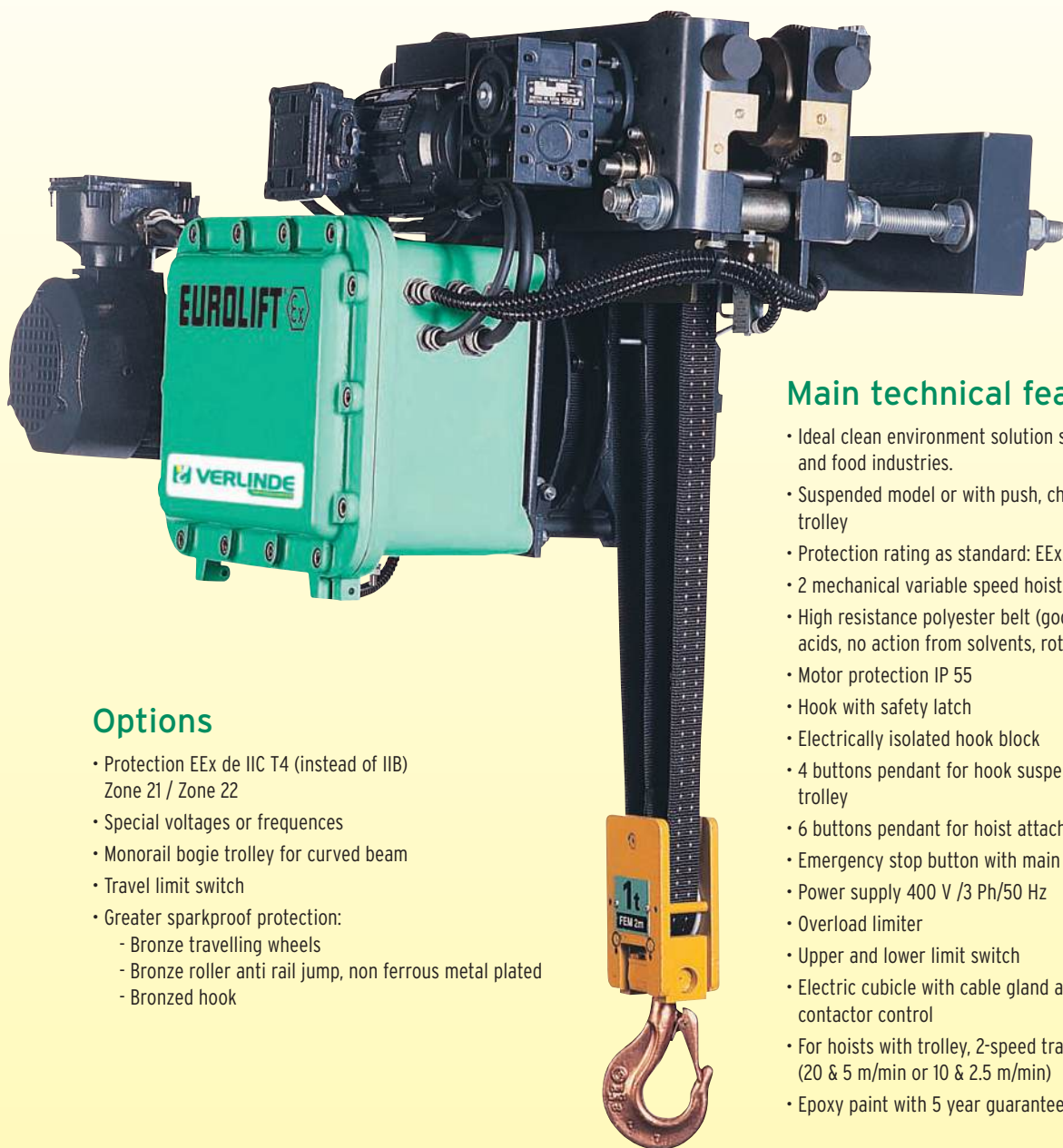

## Options

- Protection EEx de IIC T4 (instead of IIB) Zone 21 / Zone 22
- Special voltages or frequencies
- Monorail bogie trolley for curved beam
- Travel limit switch
- Greater sparkproof protection:
  - Bronze travelling wheels
  - Bronze roller anti rail jump, non ferrous metal plated
  - Bronzed hook

## Main technical features

- Ideal clean environment solution such as for chemical and food industries.
- Suspended model or with push, chain driven or electric trolley
- Protection rating as standard: EEx de IIB T4
- 2 mechanical variable speed hoisting motors
- High resistance polyester belt (good resistance to acids, no action from solvents, rotproof, antistatic)
- Motor protection IP 55
- Hook with safety latch
- Electrically isolated hook block
- 4 buttons pendant for hook suspended hoist on manual trolley
- 6 buttons pendant for hoist attached to electric trolley
- Emergency stop button with main contactor.
- Power supply 400 V /3 Ph/50 Hz
- Overload limiter
- Upper and lower limit switch
- Electric cubicle with cable gland and low voltage 48 V contactor control
- For hoists with trolley, 2-speed travelling motor (20 & 5 m/min or 10 & 2.5 m/min)
- Epoxy paint with 5 year guarantee

# EUROLIFT® BH

## **Gear box**

3-step helical gear, life-lubricated (semi-fluid grease) comprising O-ring seals and lip seal at shaft end (BH2).



## **Lifting motor**

2-speed motor, electromagnetic brake featuring automatic wear compensation.  
IP 55 protection. Class F insulation.  
Hoist motor protected by thermal sensors.

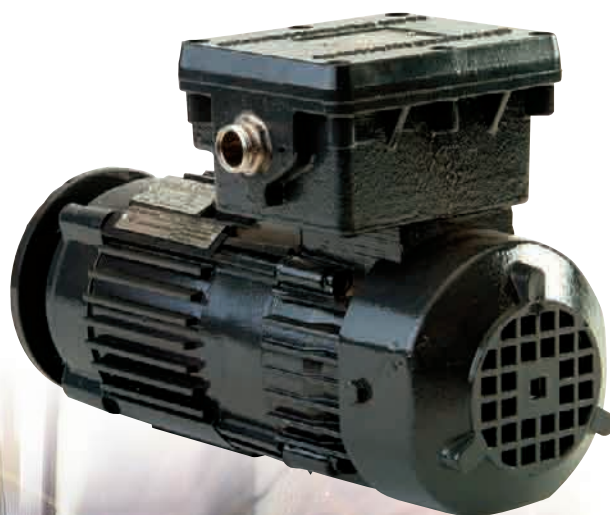

## **Electric cubicle**

- 48V low voltage control.
- Printed circuit for standard voltage.
- NFE 52070 standard
- Upper and lower limit switches IP 54
- Protected low voltage control push button box



# Explosion proof electric belt hoist

For loads from

# 500 to 5,000 kg



### Lifting block and hook

Stainless steel block and hook as options.



### BH design

The most reduced "C" approach data of hook and "F" approach data of hoist compared with competitors.

Low block shift during lifting (virtually vertical lifting). Thanks to its principle of construction EUROLIFT BH provides "virtually vertical lifting" as standard for a fine positioning of your load.

### Overload limiter

Overload limiter as standard incorporated in hoist preventing ascent in the event of overload (in compliance with "MACHINES" directive).

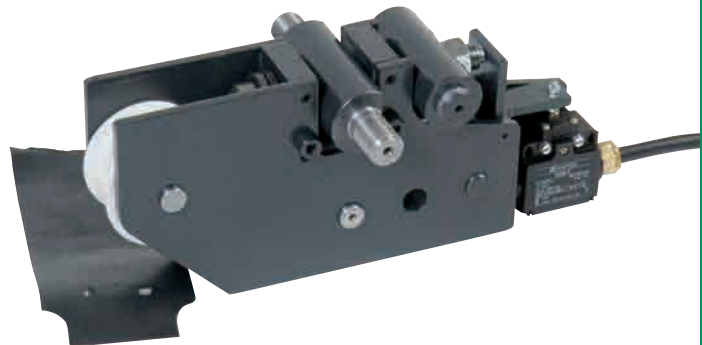

### Belt

High resistance anti-static polyester belt Flame retardant with good dimensional stability and excellent ability to maintain its strength after immersion in boiling water. Excellent ability to withstand attack by acids. Immune to attack by solvents. Rotproof BH5 : Dynema belt (this belt has the same characteristics as those of the BH2, with a greater safety factor).



# VHR<sup>®</sup>-CHD<sup>®</sup>

Type VHR Ex manual chain hoist

For loads from

**500 to 10,000 kg**



Manual trolleys and hand chain blocks designed to be used in explosive atmospheres do not have to comply with specific standards. However, the use of this type of lifting equipment of its very nature could lead to sparks (creation of particles by friction). To deal with this problem, VERLINDE's manual trolleys and hand chain blocks are available in ATEX version. Marking : Ex 11 2 Gc IICT4.

## Sparkproof manual hand chain blocks

### Main technical features

- Overload limiter as standard
- Chrome plated block shell
- ISO hooks with safety latches
- Galvanised and calibrated load chain
- 60 µm bronzed hook
- Stainless steel hand chain as option

### Options

- Corrosion proof version with stainless steel lifting chain available as option
- Chain collector as option



# VHR<sup>®</sup>-CHD<sup>®</sup>

Type VHR Ex manual trolley

For loads from

500 to 10,000 kg



Sparkproof manual travelling trolley

## Main technical features

- For loads up to 10 tonnes
- Travelling trolley operated by push action on load
- 60 µm bronze treated wheels
- Rubber buffer
- Stainless steel hand chain on travel version with handwheel and chain

## Options

- Chrome plated trolley
- Trolley with short headroom and travel with handwheel and handchain

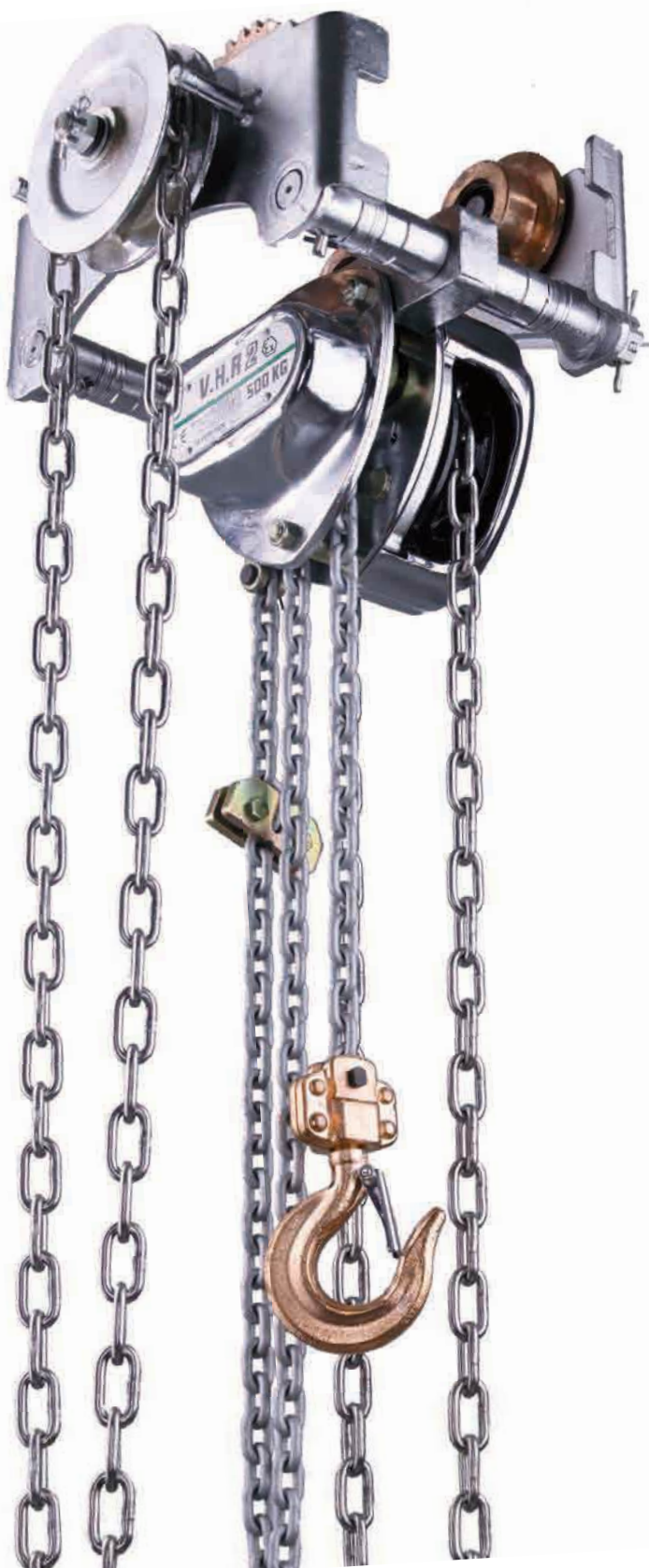

# COMPOSANTS

Double girder  
crane kit

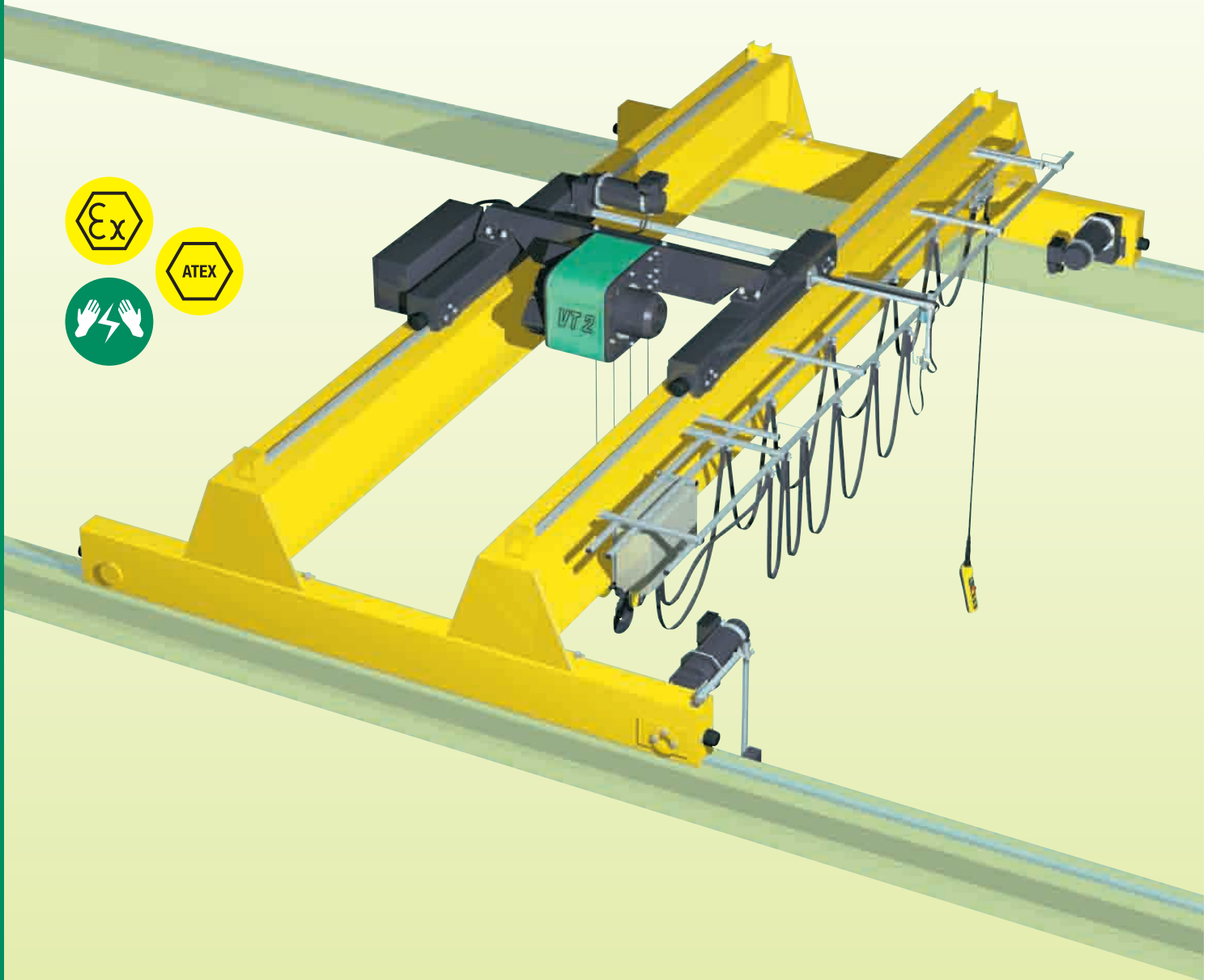

# Ex components for standart cranes

Single girder top running crane kit

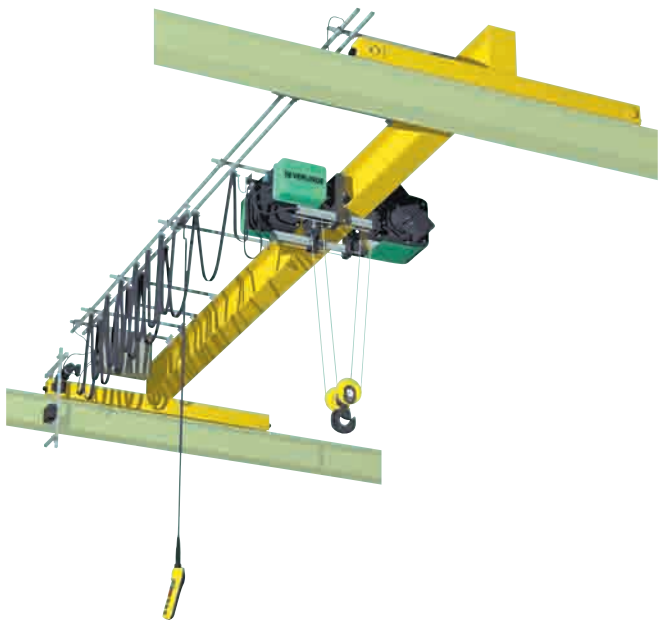

Single girder underslung crane kit



## Top running end carriage for crane Underslung end carriage for crane

### Main technical features

- Protection rating: EEx de IIB T4
- End carriages supplied with channels and adjustable trolleys
- 2 travelling speeds
- 2 geared wheels per carriage
- Drive units with brake
- Motor protection IP 55, insulation class F
- Motors thermal protection

### Options

- Special voltage
- Travel limit switch
- Tropicalized motors
- Greater sparkproof protection
- Non standard wheel groove



### Options

- Special voltage
- Travel limit switch
- Tropicalized motors
- Greater sparkproof protection
- Non standard wheel groove

### Main technical features

- Protection rating: EEx de IIB T4
- End carriages with wheels and buffers
- Motor gear with 2 travelling speeds
- Travelling motor(s) with brake(s), IP 55 protection, class F
- End carriages with top girder connection
- Motors thermal protection

## Range of crane components

- Ex remote control system

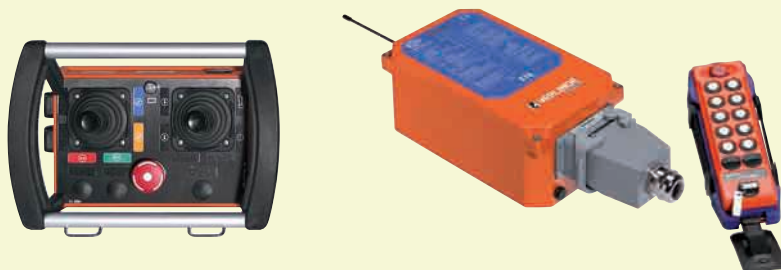

- Ex Explosion-proof power feed systems, round and flat cable types



- Ex cable gland with increased safety



- Ex lighting system



- Ex range of visual and audible warning system



- Ex push button range for hoists and cranes

- Push button box Sealed, IP 65 protection with 2, 4 or 6 buttons.
- 48V low voltage control, emergency stop button.



- Suspended crane electric cubicle

- Complete cubicle with aluminium base, and hinged steel cover - includes terminals and 48v transformer, crane travel contactors, main contactor, thermal trip relays.
- EEx ... IIB T4 protection



Option : EEx de IIC T4 protection



# VTP/VUP

## VTP manual top running or VUP suspended crane kit

### Main technical features

- Sets of components for manufacture of manual top running or underslung crane with sparkproofing features
- Girder or crane manufacturing drawings
- Support brackets for long travel drive mechanism (standard drawing supplied)
- Capacity from 500 kg up to 10 tons
- Span from 4 up to 16 m

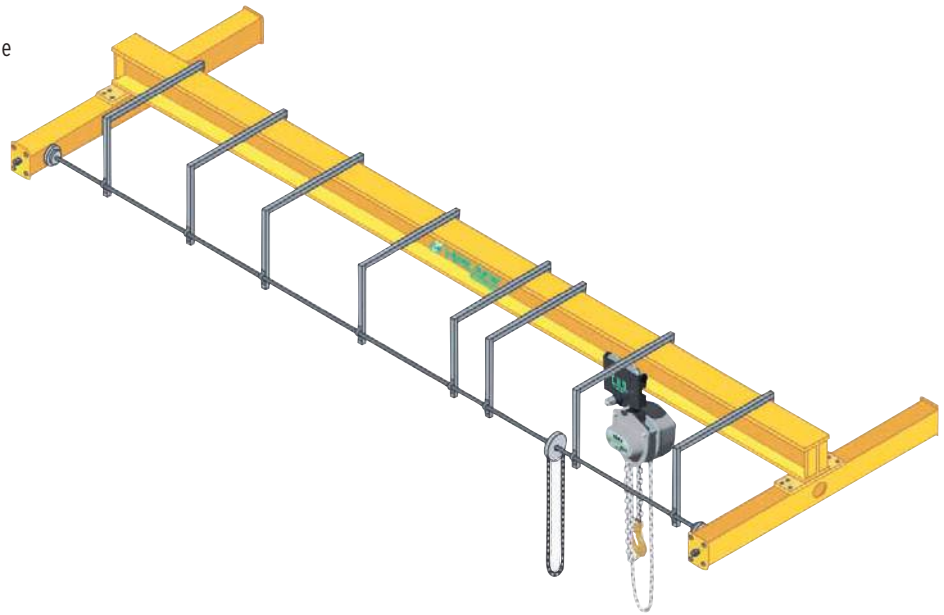

# EUROSTYLE<sup>®</sup>

## Wall or column-mounted jib cranes

### Main technical features

Explosion proof and sparkproof jib cranes : mounted on a wall or on a column, with total or partial rotation capability, manual or motorized.

Individual handling is essential to each workstation to prevent a slowdown in the production rhythm when using the travelling crane in service at the production plant.

VERLINDE offers a wide range of jib crane that are strong, with an attractive design and have high level of performance.

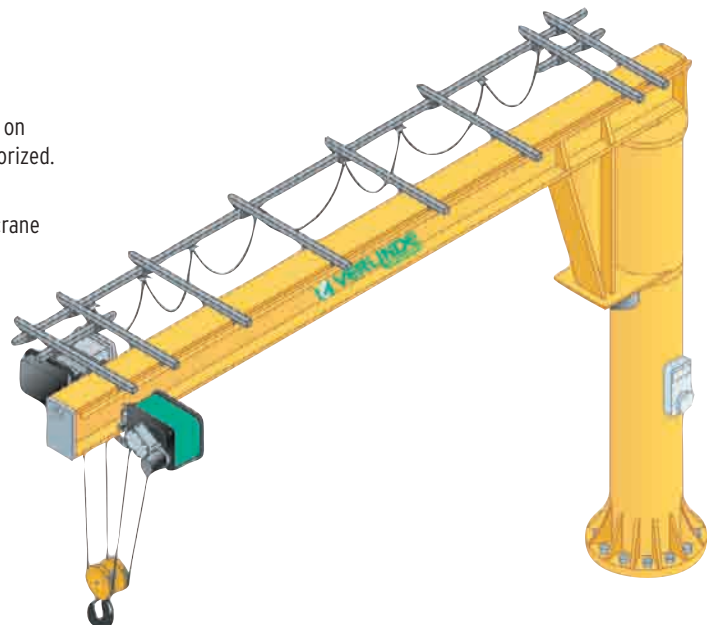

# Gas groups and temperature classes

Zone	0	1	2	Safe area
Explosive atmosphere				
Presence of explosive atmosphere	Constant or for long periods	Occasionally during normal operation	Rarely or for short periods	Practically never
Ignition sources				

## Equipment classification

Max. surface temperature	IIA	IIB	Equipment category
T1 - 450° C	Methane - Carbon Monoxide Ammonia - Acetone Toluene	Cyclopropane Cyanhydric acid	Hydrogen 2 independent faults
T2 - 300° C	Propane - Butane	Ethylene - Butadiene	
T3 - 200° C	Gas		
T4 - 135° C	Acetaldehyde		
T5 - 100° C			Carbon disulphide Ethyl nitrite
T6 - 85° C			

Installations are no longer classified as "Area" but as "Category" which takes into account both explosive gas and dust.

	Equipment category	Inflammable substances	Level of protection	Fault protection	Comparison with present practice and IEC
Groupe I (mines)	M1	Methane, dust	Very high level	2 types of protection or 2 independent faults	Group I
	M2	Methane, dust	High level	1 type of protection or normal operation	Group I
Groupe II (surface)	1	Gas, vapours, mist, dust	Very high level	2 types of protection or 2 independent faults	Group II Z0 (gas) Z20 (dust)
	2	Gas, vapours, mist, dust	High level	1 type of protection/habitual frequent malfunction	Group II Z0 (gas) Z20 (dust)
	3	Gas, vapours, mist, dust	Normal	Required level of protection	Group II Z0 (gas) Z20 (dust)

## EC marking

<b>CE</b>	...	<b>Ex</b>	<b>II</b>	<b>2</b>	<b>G</b>	<b>and</b>	<b>D</b>	<b>EEx</b>	<b>de</b>	<b>IIB</b>	<b>T4</b>		
					Gas		Dust						
					Equipment category : Present zone 1						Temperature class		
					Equipment group for surface						Explosion group		
					Use equipment for potentially explosive atmospheres								Type of protection
					Identification number of notified body								Symbol for materials manufactured in accordance with european norms
EC marking													



## VERLINDE is :

- > The leading French manufacturer and exporter of lifting and handling equipment.
- > A comprehensive range of 30 lifting devices from 60 to 160 000 kg.
- > ISO 9001 Quality Assurance Certification.



## Our references

**Metallurgy, Mechanics, Nuclear** → Sollac - Unimetal - Stein - NFM - Framatome - Neyrpic

**Chemicals, Petrochemicals industry** → Rhône-Poulenc - Du Pont De Nemours - Elf - Total - Pechiney

**Aeronautical industry** → Aérospatiale - Airbus - Eurocopter - Air France - Aéroport de Paris - Snecma - Marcel Dassault

**Agri-food industry** → Nestlé - Gervais Danone - Bel

**Automobile industry** → Renault - Peugeot - Citroën - Scania - Ford - RVI - Volkswagen - Michelin - Massey Ferguson - Manitou - Toyota Industrial Equipment

**Other sectors** → EDF - SNCF - RATP - Spie - Trindel - Lyonnaise des Eaux - Dumez - Fougerolle - GEC Alstom - Bouygues - Polysius



### In France :

A network of sales outlets, after sales service points, EUROPONT suspended crane construction units and a distributor network.

### Abroad :

A customer service in more than 55 countries.



2, boulevard de l'Industrie - B.P. 20059 - 28509 Vernouillet cedex - France

Phone : (33) 02 37 38 95 95 - Fax : (33) 02 37 38 95 99

Internet : [www.verlinde.com](http://www.verlinde.com)